

8

7

6

5

Ø% (a a 'l '&%) a a 'G\Ub\_

A %&'l '%&) 'l '%&)' a UY'h.fYUX

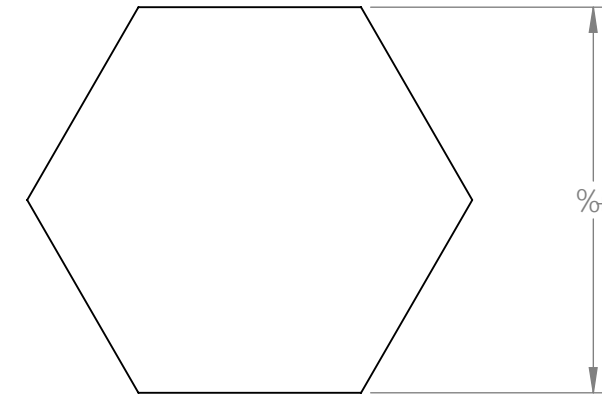
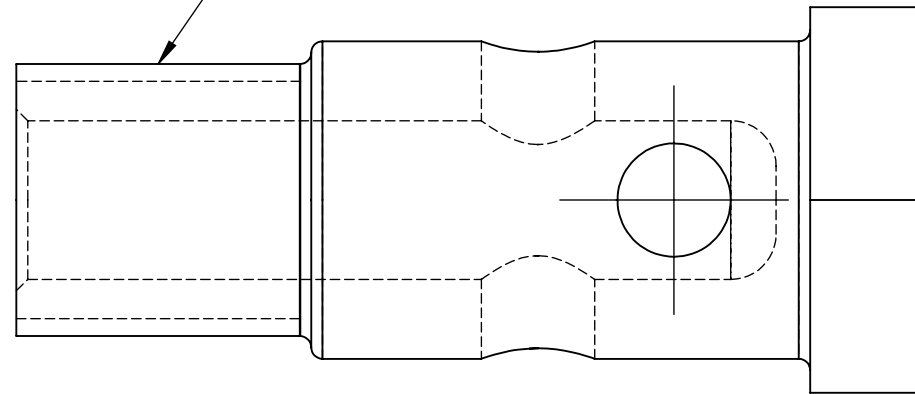
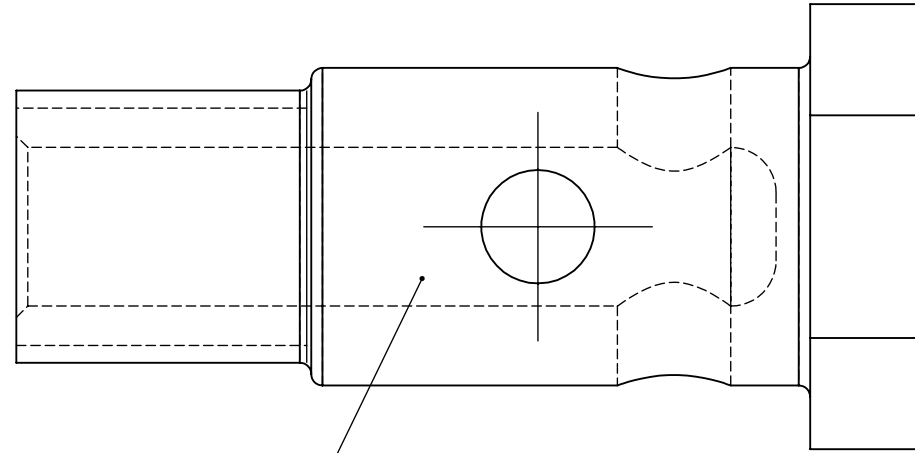
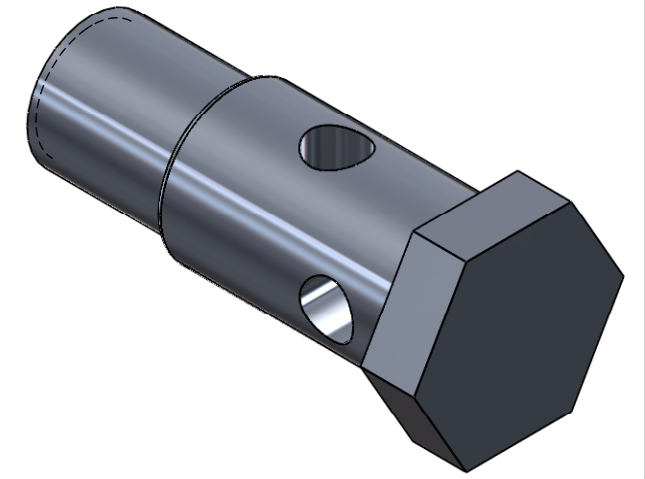

<p>Third angle</p>	<p>I B @GGC H: 9FK @9 QD97 ±.98.</p> <p>8 A 9B GC BG5F9 B B7 &lt;9G</p> <p>HC @F5B7 9G</p> <p>: F57 HC B5 @±</p> <p>5B: I @5F: A 57 &lt;±.....69B 8 ±</p> <p>HK C D@57 9897 A 5@'±</p> <p>H: F99D@57 9897 A 5@ ±</p>	B5A 9	85H9	<p><b>NORTHERN POWER PRODUCTS, INC.</b></p>
	<p>8A 9B GC BG5F9 B B7 &lt;9G</p> <p>HC @F5B7 9G</p> <p>: F57 HC B5 @±</p> <p>5B: I @5F: A 57 &lt;±.....69B 8 ±</p> <p>HK C D@57 9897 A 5@'±</p> <p>H: F99D@57 9897 A 5@ ±</p>	8F5K B	8 >	
<p>DFC DF: 5FM5B87 CB: 89BH5@</p> <p>H: 9 B: CFA 5HC B 7 C BH5 B 98 B H: G</p> <p>8F5K B: G H: 9 GC @DFC D9F HMC:</p> <p>BC FH: 9FB DC K 9F DFC 81 7 H2 B7"</p> <p>5BMF9DFC 81 7 HC B B D5FHCF 5G5"</p> <p>K &lt;C @9K H: C I HH: 9K F H9B D9FA GGCB</p> <p>C: BC FH: 9FB DC K 9F DFC 81 7 H2 B7"</p> <p>GDFC &lt; 6+98"</p>	<p>BHFD9H: 9CA 9F 7</p> <p>HC @F5B7 B: D9F.</p> <p>A 5HF 5@</p> <p>G\Uj' Ygg GHYY'</p> <p>: B G&lt;</p> <p>BcbY</p>	E "5"	7CA A 9BHG	<p>A %(!A %&amp;'l '%&amp;) 'l " )</p> <p>G\Yd!Xck b '6Ub c' 6c'h</p>
<p>5DD@7 5HC B</p>	<p>8C B CHG7 5@8F5K B:</p>	<p>6</p>	<p>8K ; "'BC "</p> <p>&lt;K \$\$\$%</p>	<p>F9J</p> <p>5</p>
		<p>G7 5 @9. (. % K 9± &lt;H'</p>		<p>G&lt;99H% C : %</p>